



# Q/Tec™ QH-Series 2 Air-to-Air Heat Pumps

**Heating Capacities: 24,000 to 47,000 BTUH**  
**Cooling Capacities: 25,000 to 52,000 BTUH**

The Q/Tec™ Series self-contained packaged heat pump is designed to be installed inside a building structure against an exterior exposed wall. Q/Tec's™ design provides "whisper" quiet operation with total comfort for the occupants at efficiency levels up to 24% above the federal standard. This design eliminates the need for roof-mounted equipment and outside condensing units and can meet your specific architectural requirements.

Q/Tec's™ "quiet technology" provides extremely low sound levels (both indoor and outdoor) by using special components and materials in the construction of the unit. By using special motors, sound insulation and sound absorbing metal we have built a heat pump system that is significantly quieter than competitive product available today.

Q/Tec™ is designed for both new construction and renovation projects for schools, modular buildings and light commercial buildings. A variety of ventilation and dehumidification options are designed to address your project's indoor air quality and dehumidification requirements.

The Q/Tec™ Series unique design allows all maintenance and service to be performed inside the building to facilitate multi-story installations. Access to air filters and controls is accomplished through a hinged front panel for easy accessibility. All Q/Tec™ Series models are built on heavy duty permanent rollers for easy installation and removal from the wall sleeve for additional service access.

Q/Tec's™ durable, easy to clean cabinet is aesthetically pleasing and comes standard with side and bottom trim pieces. Two types of cabinet finish are available: a durable two tone (slate and platinum) vinyl covered steel, or gray pre-painted steel.

## Engineered Features

### Scroll Compressor

The Copeland scroll compressor has been designed for increased efficiency, quieter operation with reduced shutdown noise and improved reliability for longer life. Eliminates need for crankcase heater and suction line accumulator.

### Phase Rotation Monitor

Standard on all 3-phase scroll compressors. Protects against reverse rotation if power supply is not properly connected.

### Indoor Blower Motor

All models feature a variable speed (ECM) motor providing super high efficiency, low sound levels and soft start capabilities. The motor is self-adjusting to provide the proper airflow rate at high static pressure for ducted installations without user adjustment or wiring changes. Optional dehumidification circuit (hot gas reheat) provides improved dehumidification when used with humidistat.

### Outdoor Fan Motor

The PSC outdoor fan motor has double oil capacity sleeve bearings and is totally enclosed for extended life.

### Copper Tube/Aluminum Fin Coils

Grooved copper tubing and enhanced aluminum fins provide maximum heat transfer and high energy efficiency. Evaporator coil constructed with hydrophilic fin stock that seals fin surface against aluminum oxide formation, is resistant to mold and mildew growth (tested to ASTM D3273, no growth) and reduces beading of condensate on the fin surface. Optional phenolic-coated coils are also available.

### Cabinet

Constructed of 20 gauge pre-painted or vinyl laminated galvanized steel. Choice of either two tone vinyl finish with "slate" front panels and "platinum" cabinet for designer appearance, or gray painted steel. Vinyl finish is very resistant to scratching and marring and is very easy to clean. Tamper resistant fasteners are provided for access panels. Unit includes built-in rollers for easy installation into wall sleeve and removal for service if necessary. Hinged, lockable front panel for filter service and access to primary functional electrical controls.

### Insulation

Cabinet is fully insulated with foil covered, high density fiberglass insulation with sealed edge treatment and special sound deadening insulation material in the compressor section. All insulation is designed to resist mold and mildew growth and facilitate ease of cleaning.

### Electrical Components

Are easily accessible for routine inspection and maintenance through front service panels. Circuit breaker standard on all 208/230V models and rotary disconnect standard on all 460V models. Circuit breaker/rotary disconnect access is through lockable access panel. Lock and key provided as standard equipment.

### Electric Heat Strips

Backup electric heat strips feature automatic limit safety controls. Heater packages are factory installed for all models. See Electric Heat Table for available options.

### Hot Water Coil

A plenum mounted hot water coil is available for both free-blow and ducted applications.

- Complies with efficiency requirements of ANSI/ASHRAE/IESNA 90.1-2007.
- Certified to ANSI/ARI Standard 390-2003 for SPVU (Single Package Vertical Units).
- Commercial Product - Not intended for Residential application.



MEA #: 127-97-E

### Air Filters

One-inch disposable panel type air filters are standard. Optional two-inch pleated and two-inch fiberglass disposable air filters are available. Optional Energy Recovery Ventilator has a separate filter for exhaust air to keep ERV clean.

### Solid State Electronic Heat Pump Control

Provides efficient 30-minute defrost cycle. A thermistor sensor and speed up terminal for service along with a 10-minute defrost override are standard on the electronic heat pump control.

### Refrigerant Service Ports

Located in filter compartment for easy access.

### Liquid Filter Dryer

Standard on all models.

### High / Low Pressure Switch

Provides refrigerant circuit high pressure and loss of charge protection. Includes lockout circuit that is resettable from room thermostat.

### Five Minute Compressor Time Delay

Provides short cycle protection for the compressor which extends compressor life. Built into the electronic heat pump control as standard.

### Ventilation Packages

Barometric fresh air damper standard on all units and allows up to 25% outside fresh air. Optional energy recovery ventilator can provide up to 450 cfm of outside air and exhaust through the unit while maintaining indoor comfort and humidity levels. Commercial room ventilator and blank-off plate are also available.

### Diagnostic Light

System service - indicates high or low pressure switch operation for compressor protection. Located inside control panel.

### Stainless Steel Drain Pans

Provides extended life of the evaporator and condenser drain pans for maximum corrosion resistance.

### Side Trim Piece Extension

Provides cabinet extension between interior wall and unit when wall thickness is between 12 inches to 14 inches. Standard feature shipped with all models. Optional trim kits for thinner walls available.

### Wall Sleeve

Constructed of 16 gauge galvanized steel, coated with epoxy primer and a baked on polyester enamel paint, which allows it to withstand 1000 hours of salt spray tests per ASTM B117-03. Required for all models. Ordered separately.



## Capacity and Efficiency Ratings

MODELS	QH243	QH302	QH362	QH422	QH482	QH602
Cooling BTUH ①	25,000	28,400	35,000	40,000	46,000	52,000
EER ②	10.60	9.50	10.00	9.00	9.50	8.60
High Temp Heating (47F) BTUH ①	23,600	27,400	32,400	38,000	43,500	47,000
COP ②	3.10	3.00	3.30	3.10	3.10	3.00
Low Temp Heating (17F) BTUH ①	14,000	15,000	20,000	25,000	27,400	31,000
COP ②	2.10	2.10	2.20	2.20	2.30	2.10

① Capacity is certified in accordance with ANSI/ARI Standard 390-2003.

② EER = Energy Efficiency Ratio, COP = Coefficient of Performance, and are certified in accordance with ANSI/ARI Standard 390-2003.

All ratings based on fresh air intake being 100% closed (no outside air introduction).

## Specifications - 2, 2½ and 3 Ton

MODELS	QH243-A	QH242-B	QH242-C	QH302-A	QH302-B	QH302-C	QH362-A	QH362-B	QH362-C
<b>ELECTRICAL RATING--60 HZ</b>	230/208 - 1	230/208 - 3	460 - 3	230/208 - 1	230/208 - 3	460 - 3	230/208 - 1	230/208 - 3	460 - 3
Operating Voltage Range	197-253		414-506	197-253		414-506	197-253		414-506
<b>COMPRESSOR-- CIRCUIT A</b>									
Voltage	230/208		460	230/208		460	230/208		460
Rated Load Amps	10.9/12.7	7.3/8.6	3.9	11.8/13.2	8.1/8.8	4.0	15.8/17.4	11.0/12.1	5.5
Branch Circuit Selection Current	12.7	8.6	3.9	13.5	9.0	4.5	17.4	12.1	5.5
Lock Rotor Amps	61/61	55/55	27	72.5/72.5	63/63	31	88/88	77/77	39
<b>FAN MOTOR &amp; CONDENSER</b>									
Fan Motor--HP-RPM-SPD	1/5 - 1075 - 1			1/5 - 1075 - 1			1/5 - 1075 - 1		
Fan Motor-- Volts-Amps	230/208 - 1.6		460 - .8	230/208 - 1.6		460 - .8	230/208 - 1.6		460 - .8
Fan--DIA-CFM	20" - 1600			20" - 1600			20" - 1600		
<b>MOTOR &amp; EVAPORATOR</b>									
Blower Motor HP-SPD	1/2 - Variable			1/2 - Variable			1/2 - Variable		
Blower Motor--Volts-Amps	230/208 - 1.8			230/208 - 2.7			230/208 - 3.3		
CFM Cooling & E.S.P. w/Filter (Rated-Wet Coil)	800 @ .10 ESP			1000 @ .15 ESP			1200 @ .15 ESP		
Filter Sizes (inches) STD.	1 - 16x20x1 & 1 - 16x16x1			1 - 16x20x1 & 1 - 16x16x1			1 - 16x20x1 & 1 - 16x16x1		
<b>SHIPPING WEIGHT--LBS.</b>	500 lb.			500 lb.			530 lb.		

## Specifications - 3½, 4 and 5 Ton

MODELS	QH422-A	QH422-B	QH422-C	QH482-A	QH482-B	QH482-C	QH602-A	QH602-B	QH602-C
<b>ELECTRICAL RATING--60 HZ</b>	230/208 - 1	230/208 - 3	460 - 3	230/208 - 1	230/208 - 3	460 - 3	230/208 - 1	230/208 - 3	460 - 3
Operating Voltage Range	197-253		414-506	197-253		414-506	197-253		414 - 506
<b>COMPRESSOR-- CIRCUIT A</b>									
Voltage	230/208		460	230/208		460	230/208		460
Rated Load Amps	19.0/20.4	13.0/13.2	6.1	19.4/22.2	13.9/14.9	6.6	24.9/28.7	17.2/18.6	9.0
Branch Circuit Selection Current	20.4	13.2	6.4	22.2	14.9	6.6	28.9	19.6	9.0
Lock Rotor Amps	109/109	88/88	44	137/137	91/91	46	148/148	123/123	62
<b>FAN MOTOR &amp; CONDENSER</b>									
Fan Motor--HP-RPM-SPD	1/5 - 1075 - 1			1/5 - 1075 - 1			1/5 - 1075 - 1		
Fan Motor--Volts-Amps	230/208 - 1.6		460 - .8	230/208 - 1.6		460 - .8	230/208 - 1.6		460 - .8
Fan--DIA-CFM	20" - 1600			20" - 1600			20" - 1600		
<b>MOTOR &amp; EVAPORATOR</b>									
Blower Motor HP-SPD	1/2 - Variable			1/2 - Variable			3/4 - Variable		
Blower Motor--Volts-Amps	230/208 - 3.7			230/208 - 3.7			230/208 - 4.9		
CFM Cooling & E.S.P. w/Filter (Rated-Wet Coil)	1200 @ .15 ESP			1400 @ .20 ESP			1550 @ .20 ESP		
Filter Sizes (inches) STD.	1 - 16x20x1 & 1 - 16x16x1			1 - 16x16x1 & 1 - 16x25x1			1 - 16x16x1 & 1 - 16x25x1		
<b>SHIPPING WEIGHT--LBS.</b>	530 lb.			560 lb.			560 lb.		

## Factory Built-in Electric Heat Table

Nominal KW	At 240V (1)				At 208V (1)				At 480V (2)			At 460V (2)		
	Kw	1-Ph Amps	3-Ph Amps	Btuh	Kw	1-Ph Amps	3-Ph Amps	Btuh	Kw	3-Ph Amps	Btuh	Kw	3-Ph Amps	Btuh
5.0	5.0	20.8		17,065	3.75	18.0		12,799						
6.0	6.0		14.4	20,478	4.50		12.5	15,359	6.0	7.2	20,478	5.52	6.9	18,840
9.0	9.0		21.7	30,717	6.75		18.7	23,038	9.0	10.8	30,717	8.28	10.4	28,260
10.0	10.0	41.7		34,130	7.50	36.1		25,598						
12.0	12.0		28.9	40,956	9.00		25.0	30,717	12.0	14.4	40,956	11.04	13.9	37,680
15.0	15.0	62.5	36.1	51,195	11.25	54.1	31.2	38,396	15.0	18.0	51,195	13.80	17.3	47,099

(1) These electric heaters are available in 230/208V units only.

(2) These electric heaters are available in 480V units only.

## Indoor Blower Performance

Model	Rated ESP.	Max. ESP ①	Rated CFM ②	Optional CFM ③	Continuous CFM ④	Dehumidification CFM ⑤	CFM @ Max ESP
QH243 ⑥	0.10	0.5	800	N/A	800	500	700
QH302	0.15	0.8	1000	N/A	1000	700	910
QH362	0.15	0.8	1200	1000	1000	850	1175
QH422	0.15	0.8	1200	1000	1000	850	1175
QH482	0.20	0.8	1400	1100	1100	850	1175
QH602	0.20	0.8	1550	1250	1250	1250	1400

**Note:** These units are equipped with a variable speed (ECM) indoor motor that automatically adjusts itself to maintain approximately the same rate of indoor airflow in both heating and cooling, dry and wet coil conditions and at both 230/208 or 460 volts.

① Max. ESP (inches WC) shown is with 1" thick disposable filter (reduced by .2 for 2" filter).

② Rated CFM (based on ducted application) for heating and cooling operation. To obtain full rated CFM on models QH362, QH422, QH482 and QH602, refer to installation instruction supplied with unit.

③ Reduced indoor airflow option to provide lowest possible indoor air sound level. Reduces system capacity performance by approximately 2%.

④ Continuous fan CFM is the total air being circulated during continuous fan mode.

⑤ Indoor airflow during periods of high humidity when system is operating under control of optional humidistat for maximum humidity reduction.

⑥ Model QH243 - - when operating on 2nd stage heating the indoor air will increase to 1000 cfm.

## Ventilation System Packages

Q-Tec models are designed to provide optional ventilation packages to meet all of your ventilation and indoor air quality requirements. All units are equipped with a barometric fresh air damper as the standard ventilation package. All ventilation packages are factory installed.

### BAROMETRIC FRESH AIR DAMPER

#### STANDARD

The barometric fresh air damper is a standard feature on all models. It allows outside ventilation air, up to 25% of the total airflow rating of the unit, to be introduced through the air inlet openings and to be mixed with the conditioned air. The damper opens during blower operation and closes when the blower is off. Adjustable blade stops allow different amounts of outside air to be introduced into the building and can be easily locked closed if required.

### BLANK OFF PLATE

#### OPTIONAL

A blank off plate covers the air inlet openings which restricts any outside air from entering the unit. The blank off plate should be utilized in applications where outside air is not required to be mixed with the conditioned air.

**NOTE:** The above vent systems are intake only without built-in exhaust capability. Building will likely require separate field installed barometric relief or mechanical exhaust elsewhere within the conditioned space. Balancing dampers in the return air grille may be required to achieve specified amount of outdoor air intake.

### COMMERCIAL ROOM VENTILATOR

#### OPTIONAL

The built-in commercial room ventilator is internally mounted and allows outside ventilation air, up to 50% of the total airflow rating of the unit, to be introduced through the air inlet openings. It includes a built-in exhaust air damper. The commercial room ventilator (CRV) is a simple and innovative approach to improving the indoor air quality by providing fresh air intake and exhaust capability through the CRV. The damper can be easily adjusted to control the amount of fresh air supplied into the building. The CRV can be controlled by indoor blower operation or field controlled based on room occupancy. Complies with ANSI/ASHRAE Standard 62.1 "Ventilation for Acceptable Indoor Air Quality."

**Two Models Available:** Spring return on power loss or deactivation - Vent Option V  
Power return (will not close on power loss) - Vent Option P

### ENERGY RECOVERY VENTILATOR

#### OPTIONAL

The energy recovery ventilator (ERV) is a highly innovative approach to meeting indoor air quality ventilation requirements as established by ANSI/ASHRAE Standard 62.1. The ERV is internally mounted and allows up to 450 CFM (depending upon speed setting) of fresh air and exhaust through the unit while maintaining superior indoor comfort and humidity levels. In most cases this can be accomplished without increasing equipment sizing or operating costs. Heat transfer efficiency is up to 64% during summer and 79% during winter conditions.

The ERV consists of a unique "rotary energy recovery cassette" that provides effective sensible and latent heat transfer capabilities during summer and winter conditions. Various control schemes are addressed including limiting ventilation during building occupancy only. The ERV has a filter for the exhaust air to keep the rotary wheels clean and free of any debris introduced through the room return air grille. The intake and exhaust rates can be independently selected. Factory set on medium intake and low exhaust.

## Commercial Room Ventilator Performance Tables

**TABLE 1**

QH242 VENTILATION MODE CFM				
Damper Position	Free Blow	Static Pressure		
		0.1	0.3	0.5
A	125	120	100	75
B	135	130	115	100
C	165	160	160	140
D	255	255	235	195
E	375	320	290	265

**TABLE 2**

QH242 COOLING & HEATING MODE CFM				
Damper Position	Free Blow	Static Pressure		
		0.1	0.3	0.5
A	220	215	200	175
B	245	235	210	185
C	255	260	245	225
D	335	335	330	290
E	385	385	360	320

**TABLE 3**

QH302 Ventilation Mode CFM QH362 Ventilation Mode CFM QH422 Ventilation Mode CFM QH482 Ventilation Mode CFM				
Damper Position	Free Blow	Static Pressure		
		0.1	0.2	0.3
A	140	135	125	120
B	180	170	160	160
C	220	210	205	195
D	315	315	315	290
E	410	400	385	380

**TABLE 4**

QH302 COOLING & HEATING MODE CFM QH362 LOW SPEED COOLING & HEATING MODE CFM QH422 LOW SPEED COOLING & HEATING MODE CFM QH482 LOW APEED COOLING & HEATING MODE CFM				
Damper Position	Free Blow	Static Pressure		
		0.1	0.3	0.5
A	235	230	225	220
B	265	250	245	240
C	325	315	300	290
D	400	400	390	380
E	465	460	445	430

**TABLE 5**

QH362 HIGH SPEED COOLING & HEATING MODE CFM QH422 HIGH SPEED COOLING & HEATING MODE CFM QH482 HIGH SPEED COOLING & HEATING MODE CFM				
Damper Position	Free Blow	Static Pressure		
		0.1	0.3	0.5
A	255	250	250	230
B	285	280	280	280
C	360	360	350	345
D	445	445	445	440
E	500	500	500	490

**TABLE 6**

QH602 VENTILATION MODE CFM				
Damper Position	Free Blow	Static Pressure		
		0.1	0.3	0.5
A	185	185	180	180
B	215	215	210	200
C	290	290	280	275
D	370	370	365	350
E	465	465	455	445

**TABLE 7**

QH602 COOLING & HEATING MODE CFM				
Damper Position	Free Blow	Static Pressure		
		0.1	0.3	0.5
A	235	230	230	215
B	265	260	255	255
C	350	350	345	340
D	470	470	455	450
E	580	570	565	560

*NOTE: Ventilation airflow will increase up to 50 CFM during backup or emergency heat operation due to increased total airflow.*

# Energy Recovery Ventilator Performance Tables

## SUMMER COOLING PERFORMANCE (INDOOR DESIGN CONDITIONS 75° DB / 62° WB)

Ambient O.D.	VENTILATION RATE – 450 CFM 65% Efficiency						VENTILATION RATE – 375 CFM 66% Efficiency						VENTILATION RATE – 300 CFM 67% Efficiency							
	DB/WB DegreesF	VLT	VLS	VLL	HRT	HRS	HRL	VLT	VLS	VLL	HRT	HRS	HRL	VLT	VLS	VLL	HRT	HRS	HRL	
75	21465	14580	6884	13952	9477	4475	17887	12150	5737	11805	8018	3786	14310	9720	4590	9587	6512	3075		
	105	70	14580	14580	0	9477	9477	0	12150	12150	0	8018	8018	0	9720	9720	0	6512	6512	0
	65	14580	14580	0	9477	9477	0	12150	12150	0	8018	8018	0	9720	9720	0	6512	6512	0	
100	80	31590	12150	19440	20533	7897	12635	26325	10125	16200	17374	6682	10692	21060	8100	12960	14110	5427	8683	
	75	21465	12150	9314	13952	7897	6054	17887	10125	7762	11805	6682	5123	14310	8100	6210	9587	5427	4160	
	70	12352	12150	202	8029	7897	131	10293	10125	168	6793	6682	111	8235	8100	135	5517	5427	90	
	65	12150	12150	0	7897	7897	0	10125	10125	0	6682	6682	0	8100	8100	0	5427	5427	0	
	60	12150	12150	0	7897	7897	0	10125	10125	0	6682	6682	0	8100	8100	0	5427	5427	0	
95	80	31590	9720	21870	20533	6318	14215	26325	8100	18225	17374	5345	12028	21060	6480	14580	14110	4341	9768	
	75	21465	9720	11744	13952	6318	7634	17887	8100	9787	11805	5345	6459	14310	6480	7830	9587	4341	5246	
	70	12352	9720	2632	8029	6318	1711	10293	8100	2193	6793	5345	1447	8235	6480	1755	5517	4341	1175	
	65	9720	9720	0	6318	6318	0	8100	8100	0	5345	5345	0	6480	6480	0	4341	4341	0	
	60	9720	9720	0	6318	6318	0	8100	8100	0	5345	5345	0	6480	6480	0	4341	4341	0	
90	80	31590	7290	24300	20533	4738	15794	26325	6075	20250	17374	4009	13365	21060	4860	16200	14110	3256	10854	
	75	21465	7290	14175	13952	4738	9213	17887	6075	11812	11805	4009	7796	14310	4860	9450	9587	3256	6331	
	70	12352	7290	5062	8029	4738	3290	10293	6075	4218	6793	4009	2784	8235	4860	3375	5517	3256	2261	
	65	7290	7290	0	4738	4738	0	6075	6075	0	4009	4009	0	4860	4860	0	3256	3256	0	
	60	7290	7290	0	4738	4738	0	6075	6075	0	4009	4009	0	4860	4860	0	3256	3256	0	
85	80	31590	4860	26730	20533	3159	17374	26325	4050	22275	17374	2672	14701	21060	3240	17820	14110	2170	11939	
	75	21465	4860	16605	13952	3159	10793	17887	4050	13837	11805	2672	9132	14310	3240	11070	9857	2170	7416	
	70	12352	4860	7492	8029	3159	4870	10293	4050	6243	6793	2672	4120	8235	3240	4995	5517	2170	3346	
	65	4860	4860	0	3159	3159	0	4050	4050	0	2672	2672	0	3240	3240	0	2170	2170	0	
	60	4860	4860	0	3159	3159	0	4050	4050	0	2672	2672	0	3240	3240	0	2170	2170	0	
80	75	21465	2430	19035	13952	1579	12372	17887	2025	15862	11805	1336	10469	14310	1620	12690	9587	1085	8502	
	70	12352	2430	9922	8029	1579	6449	10293	2025	8268	6793	1336	5457	8235	1620	6615	5517	1085	4432	
	65	4252	2430	1822	2764	1579	1184	3543	2025	1518	2338	1336	1002	2835	1620	1215	1899	1085	814	
	60	2430	2430	0	1579	1579	0	2025	2025	0	1336	1336	0	1620	1620	0	1085	1085	0	
75	70	12352	0	12352	8029	0	8029	10293	0	10293	6793	0	6793	8235	0	8235	5517	0	5517	
	65	4252	0	4252	2764	0	2764	3543	0	3543	2338	0	2338	2835	0	2835	1899	0	1899	
	60	0	0	0	0	0	0	0	0	0	0	0	0	0	0	0	0	0	0	

**LEGEND**

- VLT = Ventilation Load – Total
- VLS = Ventilation Load – Sensible
- VLL = Ventilation Load – Latent
- HRT = Heat Recovery – Total
- HRS = Heat Recovery – Sensible
- HRL = Heat Recovery – Latent

## WINTER HEATING PERFORMANCE (INDOOR DESIGN CONDITIONS 70° F DB)

Ambient O.D.	VENTILATION RATE					
	450 CFM 80% Eff.		375 CFM 81% Eff.		300 CFM 82% Eff.	
	WVL	WHR	WVL	WHR	WVL	WHR
65	2430	1944	2025	1640	1620	1328
60	4860	3888	4050	3280	3240	2656
55	7290	5832	6075	4920	4860	3985
50	9720	7776	8100	6561	6480	5313
45	12150	9720	10125	8201	8100	6642
40	14580	11664	12150	9841	9720	7970
35	17010	13608	14175	11481	11340	9298
30	19440	15552	16200	13122	12960	10627
25	21870	17496	18225	14762	14580	11955
20	24300	19440	20250	16402	16200	13284
15	26730	21384	22275	18042	17820	14612

**LEGEND**

- WVL = Winter Ventilation Load
- WHR = Winter Heat Recovery

NOTE: Sensible performance only is shown for winter application.

# Installation Overview

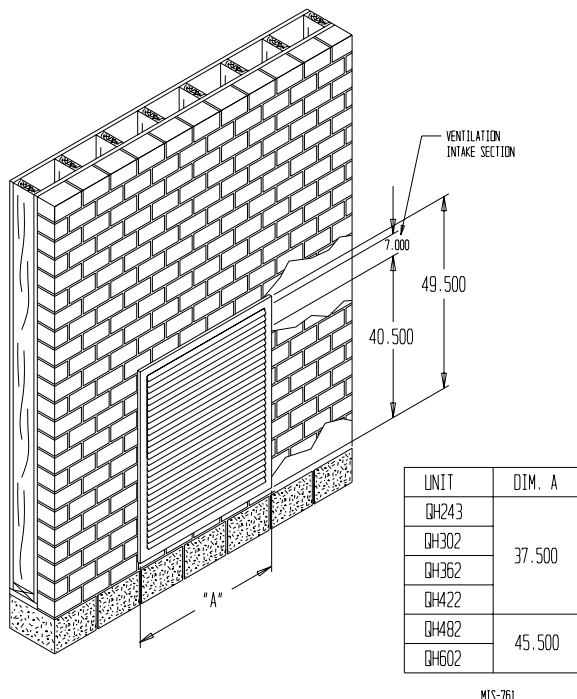

Outside louver grille

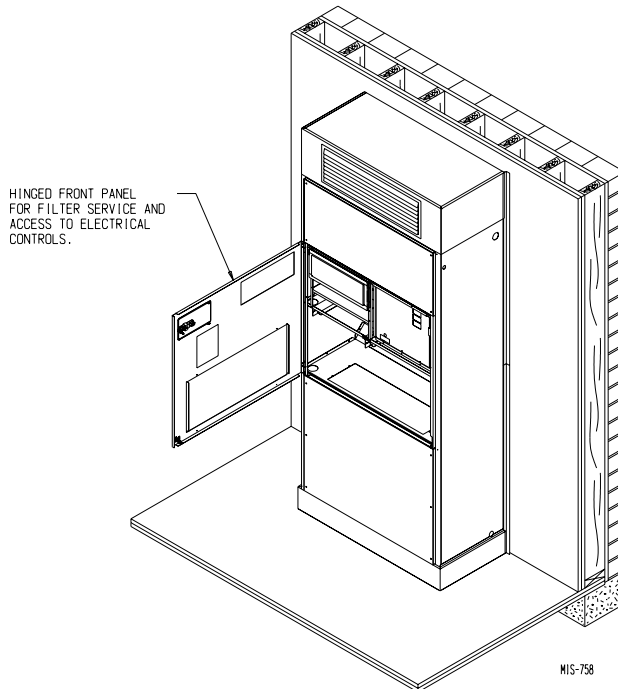

Unit installed with free blow plenum box

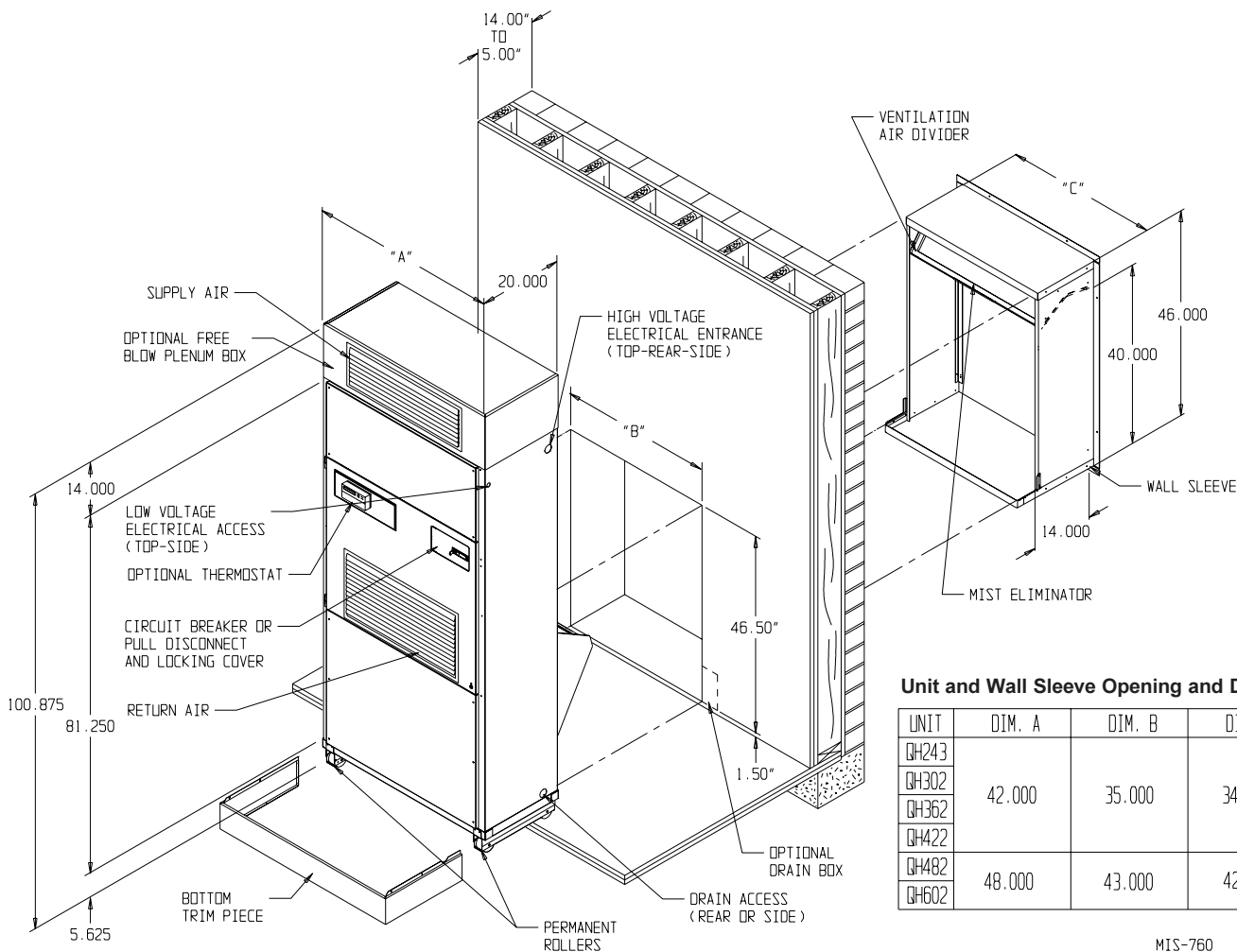

Unit and Wall Sleeve Opening and Dimensions

UNIT	DIM. A	DIM. B	DIM. C
QH243	42.000	35.000	34.000
QH302			
QH362			
QH422			
QH482	48.000	43.000	42.000
QH602			

MIS-760

# Dimensions of Basic Unit for Architectural and Installation Requirements (Nominal)

DIMENSION CHART					
UNIT	DIM. A	DIM. B	DIM. C	DIM. D	DIM. E
QH243	7.625	42.000	30.000	30.000	43.000
QH302					
QH362					
QH422					
QH482					
QH602	10.625	48.000	40.000	40.000	49.000

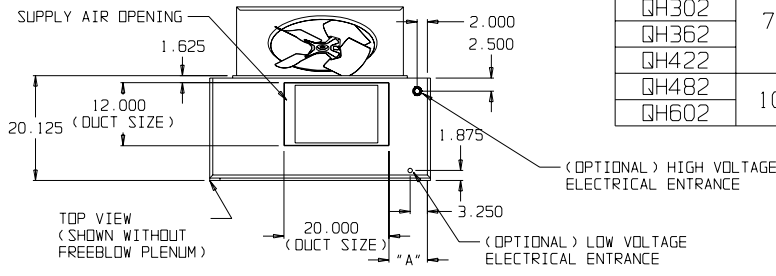

**Drawings are not to scale**

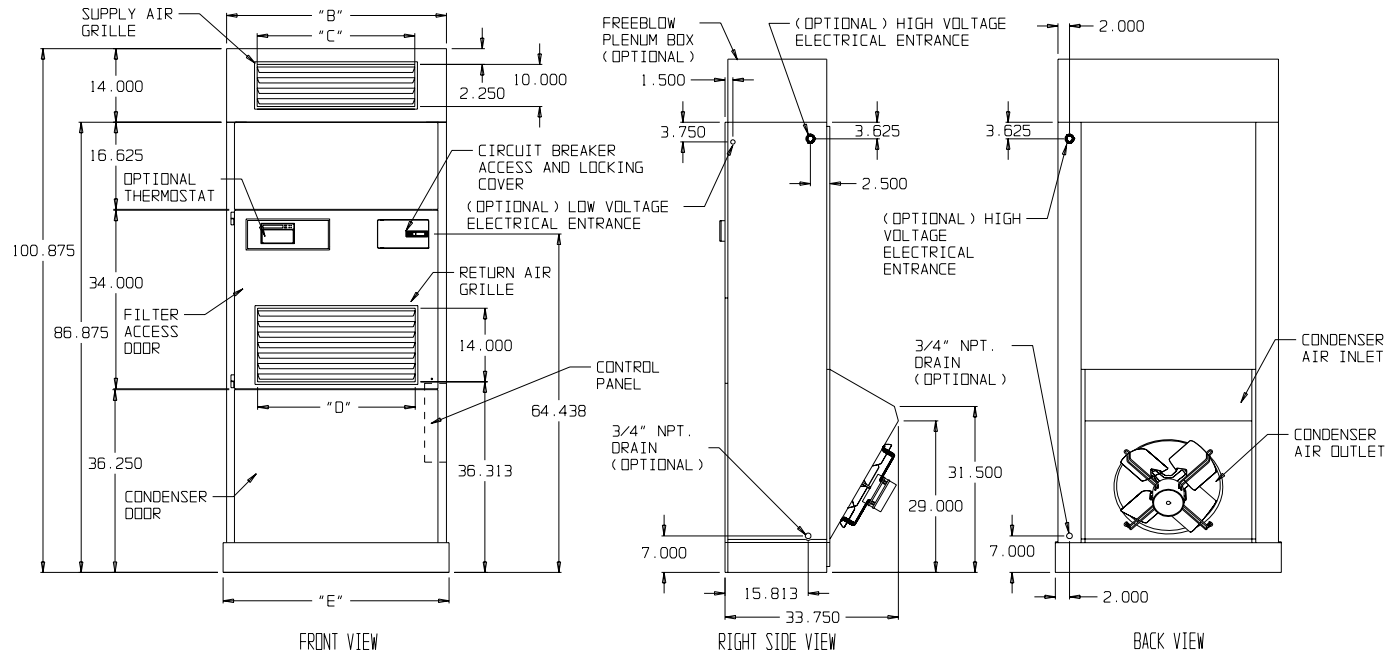

MIS-1572 A

## Optional Hot Water Coil Performance - Heating Capacity @ 180°F Water and 70°F Return Air

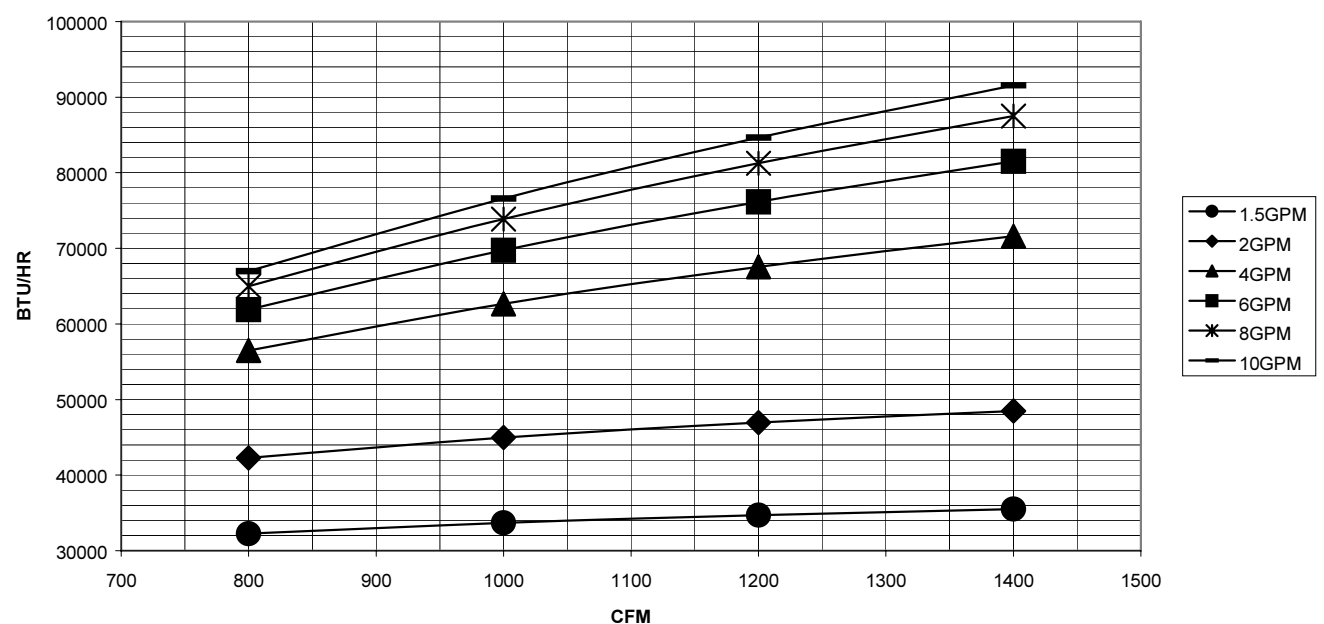

## Electrical Specifications - Standard Models

Model	Rated Volts and Phase	Single Circuit					Dual Circuit							
		No. Field Power Circuits	③ Minimum Circuit Ampacity	① Maximum External Fuse or Ckt. Brkr.	② Field Power Wire Size	④ Ground Wire	③ Minimum Circuit Ampacity		① Maximum External Fuse or Ckt. Breaker		② Field Power Wire Size		④ Ground Wire Size	
							Ckt. A	Ckt. B	Ckt. A	Ckt. B	Ckt. A	Ckt. B	Ckt. A	Ckt. B
QH243-A0Z	230/208-1	1	22	30	10	10	-	-	-	-	-	-	-	-
A05		1	47	50	8	10	-	-	-	-	-	-	-	-
A10		1 or 2	72	80	4	8	22	50	30	50	10	8	10	10
QH243-B0Z	230/208-3	1	17	20	12	12	-	-	-	-	-	-	-	-
B06		1	35	35	8	10	-	-	-	-	-	-	-	-
B09		1	44	45	8	10	-	-	-	-	-	-	-	-
QH243-C0Z	460-3	1	8	15	14	14	-	-	-	-	-	-	-	-
C06		1	17	20	12	12	-	-	-	-	-	-	-	-
C09		1	22	25	10	10	-	-	-	-	-	-	-	-
QH302-A0Z	230/208-1	1	24	35	8	10	-	-	-	-	-	-	-	-
A05		1	49	50	8	10	-	-	-	-	-	-	-	-
A10		1 or 2	74	80	4	8	24	50	30	50	10	8	10	10
QH302-B0Z	230/208-3	1	18	25	10	10	-	-	-	-	-	-	-	-
B06		1	36	40	8	10	-	-	-	-	-	-	-	-
B09		1	45	45	8	10	-	-	-	-	-	-	-	-
B12	1	54	60	6	10	-	-	-	-	-	-	-	-	
QH302-C0Z	460-3	1	9	15	14	14	-	-	-	-	-	-	-	-
C06		1	18	20	12	12	-	-	-	-	-	-	-	-
C09		1	23	25	10	10	-	-	-	-	-	-	-	-
C12	1	27	30	10	10	-	-	-	-	-	-	-	-	
QH362-A0Z	230/208-1	1	29	45	8	10	-	-	-	-	-	-	-	-
A05		1	54	60	6	10	-	-	-	-	-	-	-	-
A10		1 or 2	79	90	4	8	29	50	40	50	8	8	10	10
④ A15	1 or 2	82	90	4	8	32	50	40	50	8	8	10	10	
QH362-B0Z	230/208-3	1	23	30	10	10	-	-	-	-	-	-	-	-
B06		1	41	45	8	10	-	-	-	-	-	-	-	-
B09		1	50	50	8	10	-	-	-	-	-	-	-	-
④ B15	1	52	60	6	10	-	-	-	-	-	-	-	-	
QH362-C0Z	460-3	1	11	15	14	14	-	-	-	-	-	-	-	-
C06		1	20	20	12	12	-	-	-	-	-	-	-	-
C09		1	24	30	10	10	-	-	-	-	-	-	-	-
④ C15	1	26	30	10	10	-	-	-	-	-	-	-	-	
QH422-A0Z	230/208-1	1	33	50	8	10	-	-	-	-	-	-	-	-
A05		1	58	60	6	10	-	-	-	-	-	-	-	-
A10		1 or 2	83	90	4	8	33	50	40	50	8	8	10	10
④ A15	1 or 2	83	90	4	8	33	50	40	50	8	8	10	10	
QH422-B0Z	230/208-3	1	24	30	10	10	-	-	-	-	-	-	-	-
B06		1	43	50	8	10	-	-	-	-	-	-	-	-
B09		1	52	60	6	10	-	-	-	-	-	-	-	-
④ B15	1	52	60	6	10	-	-	-	-	-	-	-	-	
QH422-C0Z	460-3	1	12	15	14	14	-	-	-	-	-	-	-	-
C06		1	21	25	10	10	-	-	-	-	-	-	-	-
C09		1	26	30	10	10	-	-	-	-	-	-	-	-
④ C15	1	26	30	10	10	-	-	-	-	-	-	-	-	
QH482-A0Z	230/208-1	1	36	50	8	10	-	-	-	-	-	-	-	-
A05		1 or 2	61	70	6	8	36	25	50	25	8	10	10	10
A10		1 or 2	86	90	3	8	36	50	50	50	8	8	10	10
④ A15	1 or 2	86	90	3	8	36	50	50	50	8	8	10	10	
QH482-B0Z	230/208-3	1	26	40	8	10	-	-	-	-	-	-	-	-
B06		1	44	50	8	10	-	-	-	-	-	-	-	-
B09		1	53	60	6	10	-	-	-	-	-	-	-	-
④ B15	1	53	60	6	10	-	-	-	-	-	-	-	-	
QH482-C0Z	460-3	1	14	15	14	14	-	-	-	-	-	-	-	-
C06		1	23	25	10	10	-	-	-	-	-	-	-	-
C09		1	27	30	10	10	-	-	-	-	-	-	-	-
④ C15	1	27	30	10	10	-	-	-	-	-	-	-	-	
QH602-A0Z	230/208-1	1	46	60	8	10	-	-	-	-	-	-	-	-
A05		1 or 2	71	80	4	8	46	25	60	25	8	10	10	10
A10		1 or 2	96	110	3	6	46	50	60	50	8	8	10	10
④ A15	1 or 2	96	110	3	6	46	50	60	50	8	8	10	10	
QH602-B0Z	230/208-3	1	31	45	8	10	-	-	-	-	-	-	-	-
B09		1	58	70	6	8	-	-	-	-	-	-	-	-
④ B15		1	58	70	6	8	-	-	-	-	-	-	-	-
QH602-C0Z	460-3	1	17	25	10	10	-	-	-	-	-	-	-	-
C09		1	30	35	8	10	-	-	-	-	-	-	-	-
④ C15		1	30	35	8	10	-	-	-	-	-	-	-	-

① Maximum size of the time delay fuse or HACR type circuit breaker for protection of field wiring conductors.

② Based on 75°C copper wire. All wiring must conform to the National Electrical Code and all local codes.

③ These "Minimum Circuit Ampacity" values are to be used for sizing the field power conductors. Refer to the National Electric Code (latest revision), article 310 for power conductor sizing.

**Caution:** When more than one field power conductor circuit is run through one conduit, the conductors must be derated. Pay special attention to note 8 of table 310 regarding Ampacity Adjustment Factors when more than three conductors are in a raceway.

④ Maximum KW that can operate with heat pump on is 10KW. Other 5KW energizes during emergency heat only.

⑤ Maximum KW that can operate with heat pump on is 9KW. Other 6KW energizes during emergency heat only.

Note: For electrical specifications on "low ampacity" circuit models, please refer to supplemental instruction sheet 7960-371.



## Electrical Specifications - Dehumidification Models

Model	Rated Volts and Phase	Single Circuit					Dual Circuit							
		No. Field Power Circuits	①	②	③	④	⑤		⑥		⑦		⑧	
			Minimum Circuit Ampacity	Maximum External Fuse or Circuit Breaker	Field Power Wire Size	Ground Wire Size	Minimum Circuit Ampacity	Maximum External Fuse or Circuit Breaker	Field Power Wire Size	Ground Wire Size	Minimum Circuit Ampacity	Maximum External Fuse or Circuit Breaker	Field Power Wire Size	Ground Wire Size
CKT A	CKT B	CKT A	CKT B	CKT A	CKT B	CKT A	CKT B	CKT A	CKT B	CKT A	CKT B			
QH244DA0Z DA05 DA10	230/208-1	1	22	30	10	10	--	--	--	--	--	--	--	--
		1	47	50	8	10	--	--	--	--	--	--	--	
		1 OR 2	72	80	4	8	22	50	30	50	10	8	10	10
QH244DB0Z DB06 DB09	230/208-3	1	17	20	12	12	--	--	--	--	--	--	--	--
		1	35	35	8	10	--	--	--	--	--	--	--	
		1	44	45	8	10	--	--	--	--	--	--	--	
QH244DC0Z DC06 DC09	460-3	1	8	15	14	14	--	--	--	--	--	--	--	--
		1	17	20	12	12	--	--	--	--	--	--	--	
		1	22	25	10	10	--	--	--	--	--	--	--	
QH303DA0Z DA05 DA10	230/208-1	1	24	35	8	10	--	--	--	--	--	--	--	--
		1	49	50	8	10	--	--	--	--	--	--	--	
		1 OR 2	74	80	4	8	24	50	30	50	10	8	10	10
QH303DB0Z DB06 DB09 DB12	230/208-3	1	18	25	10	10	--	--	--	--	--	--	--	--
		1	36	40	8	10	--	--	--	--	--	--	--	
		1	45	45	8	10	--	--	--	--	--	--	--	
		1	54	60	6	10	--	--	--	--	--	--	--	
QH303DC0Z DC06 DC09 DC12	460-3	1	9	15	14	14	--	--	--	--	--	--	--	--
		1	18	20	12	12	--	--	--	--	--	--	--	
		1	23	25	10	10	--	--	--	--	--	--	--	
		1	27	30	10	10	--	--	--	--	--	--	--	
QH363DA0Z DA05 DA10 ④ DA15	230/208-3	1	29	45	8	10	--	--	--	--	--	--	--	--
		1	54	60	6	10	--	--	--	--	--	--	--	
		1 OR 2	79	90	4	8	29	50	40	50	8	8	10	10
		1 OR 2	82	90	4	8	32	50	40	50	8	8	10	10
QH363DB0Z DB06 DB09 ⑤ DB15	230/208-3	1	23	30	10	10	--	--	--	--	--	--	--	--
		1	41	45	8	10	--	--	--	--	--	--	--	
		1	50	50	8	10	--	--	--	--	--	--	--	
		1	52	60	6	10	--	--	--	--	--	--	--	
QH363DC0Z DC06 DC09 ⑤ DC15	460-3	1	11	15	14	14	--	--	--	--	--	--	--	--
		1	20	20	12	12	--	--	--	--	--	--	--	
		1	24	30	10	10	--	--	--	--	--	--	--	
		1	26	30	10	10	--	--	--	--	--	--	--	
QH423DA0Z DA05 DA10 ④ DA15	230/208-1	1	33	50	8	10	--	--	--	--	--	--	--	--
		1	58	60	6	10	--	--	--	--	--	--	--	
		1 or 2	83	90	4	8	33	50	40	50	8	8	10	10
		1 or 2	83	90	4	8	33	50	40	50	8	8	10	10
QH423DB0Z DB06 DB09 ⑤ DB15	230/208-3	1	24	30	10	10	--	--	--	--	--	--	--	--
		1	43	50	8	10	--	--	--	--	--	--	--	
		1	52	60	6	10	--	--	--	--	--	--	--	
		1	52	60	6	10	--	--	--	--	--	--	--	
QH423DC0Z DC06 DC09 ⑤ DC15	460-3	1	12	15	14	14	--	--	--	--	--	--	--	--
		1	21	25	10	10	--	--	--	--	--	--	--	
		1	26	30	10	10	--	--	--	--	--	--	--	
		1	26	30	10	10	--	--	--	--	--	--	--	
QH483DA0Z DA05 DA10 ④ DA15	230/208-1	1	36	50	8	10	--	--	--	--	--	--	--	--
		1	61	70	6	8	36	25	50	25	8	10	10	10
		1 or 2	86	90	3	8	36	50	50	50	8	8	10	10
		1 or 2	86	90	3	8	36	50	50	50	8	8	10	10
QH483DB0Z DB06 DB09 ⑤ DB15	230/208-3	1	26	40	8	10	--	--	--	--	--	--	--	--
		1	44	50	8	10	--	--	--	--	--	--	--	
		1	53	60	6	10	--	--	--	--	--	--	--	
		1	53	60	6	10	--	--	--	--	--	--	--	
QH483DC0Z DC06 DC09 ⑤ DC15	460-3	1	14	15	14	14	--	--	--	--	--	--	--	--
		1	23	25	10	10	--	--	--	--	--	--	--	
		1	27	30	10	10	--	--	--	--	--	--	--	
		1	27	30	10	10	--	--	--	--	--	--	--	
QH603DA0Z DA05 DA10 DA15	230/208-1	1	48	60	8	10	--	--	--	--	--	--	--	--
		1 or 2	73	80	4	8	48	25	60	25	8	10	10	10
		1 or 2	98	110	3	6	48	50	60	50	8	8	10	10
		1 or 2	98	110	3	6	48	50	60	50	8	8	10	10
QH603DB0Z DB09 DB15	230/208-3	1	31	45	8	10	--	--	--	--	--	--	--	--
		1	59	70	6	8	--	--	--	--	--	--	--	
		1	59	70	6	8	--	--	--	--	--	--	--	
QH603DC0Z DC09 DC15	460-3	1	17	25	10	10	--	--	--	--	--	--	--	--
		1	30	35	8	10	--	--	--	--	--	--	--	
		1	30	35	8	10	--	--	--	--	--	--	--	

① Maximum size of the time delay fuse or HACR type circuit breaker for protection of field wiring conductors.

② Based on 75°C copper wire. All wiring must conform to the National Electrical Code and all local codes.

③ These "Minimum Circuit Ampacity" values are to be used for sizing the field power conductors. Refer to the National Electric Code (latest revision), article 310 for power conductor sizing.

**Caution:** When more than one field power conductor circuit is run through one conduit, the conductors must be derated. Pay special attention to note 8 of table 310 regarding Ampacity Adjustment Factors when more than three conductors are in a raceway.

④ Maximum KW that can operate with heat pump on is 10KW. Other 5KW energizes during emergency heat only.

⑤ Maximum KW that can operate with heat pump on is 9KW. Other 6KW energizes during emergency heat only.

Note: For electrical specifications on "low ampacity" circuit models, please refer to supplemental instruction sheet 7960-371.



## QSP-Series Sound Plenum

The QSP3 - QSP5 Series Sound Plenum has been designed for use with ALL Bard Q-Tec Series units, both Generation I and Generation II systems. Installation is quick and easy with removal/replacement of six existing screws from the unit cabinet. Once installed the sound plenum enhances the current quiet operation of the Q-Tec Series units, and the hinged door with cam locks provides easy access to the basic Q-Tec system. Model selection is based on equipment cabinet size and finish.

Sound Plenum Pt#	Cabinet Finish	Equipment Selection
QSP3-4	Painted Steel - Gray	QH24-42
QSP3-V	Texture Vinyl ①	QH24-42
QSP5-4	Painted Steel - Gray	QH48-60
QSP5-V	Texture Vinyl ①	QH48-60

① Front Panels Slate Finish, Side Panels Platinum Gray matching Q-tec vinyl cabinet finishes.

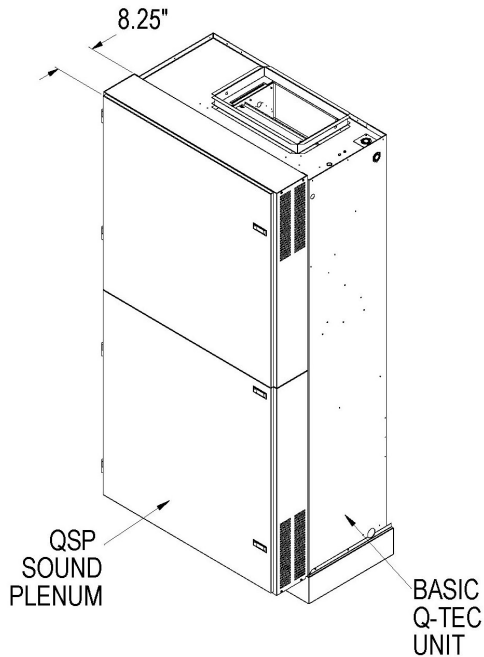

### Features:

- Two Plenum Finishes To Match Unit Cabinets
  - Vinyl or Painted Steel
- Compatible With New or Existing Units
- Removable Cam Lock Hinge Doors
- Easy Unit Service Access
- Sound Absorbing Insulation
- Reduces Equipment dBA Operating Levels
  - Up to 5 dBA with Energy Recovery Ventilator option.
  - Provides general muffling of basic unit operation. Actual sound reduction may vary depending on system operating conditions and other site variables.

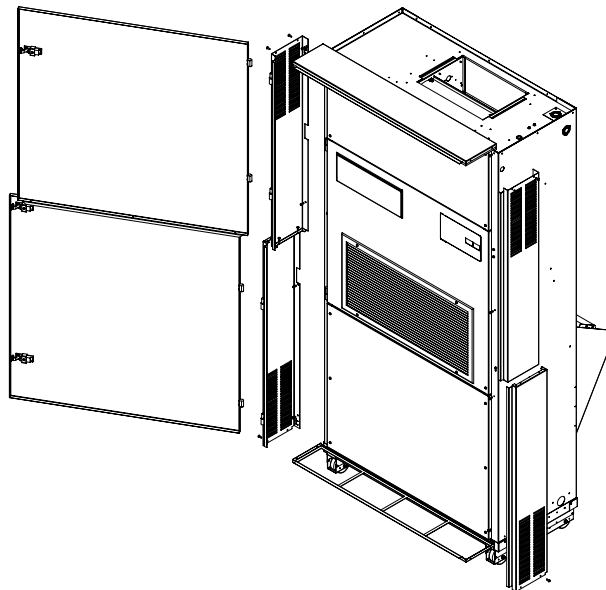

# Q/Tec™ Model Nomenclature

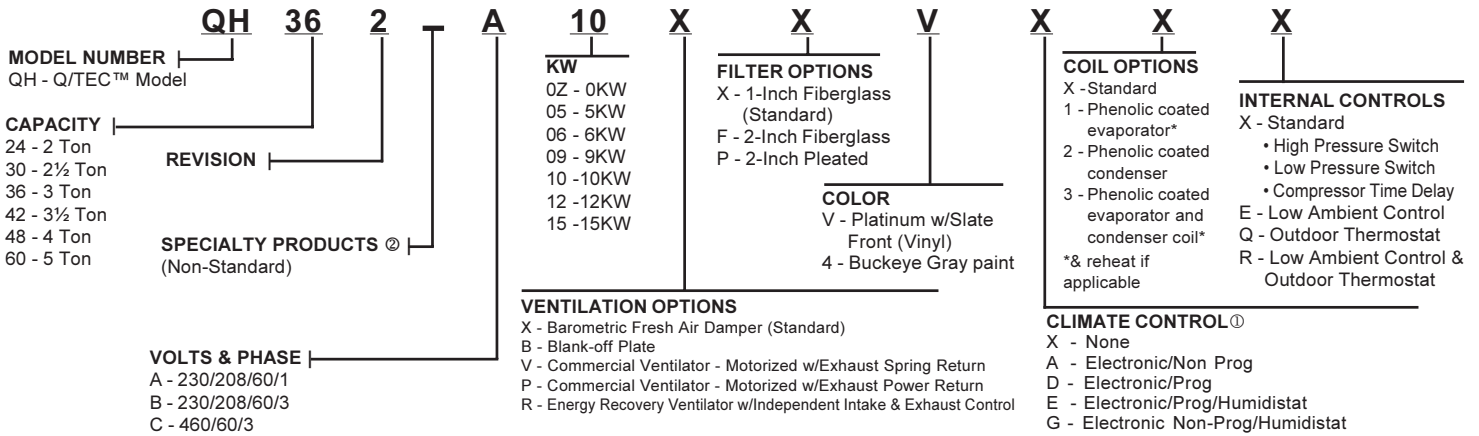

**NOTE:** ① Climate control option "X", "E" or "G" must be ordered in conjunction with the dehumidification circuit. If "X" control option is selected, humidistat must be field supplied. For CS2000A2 applications order "X" control option for field supplied and installed thermostat and humidistat, or "G" control option for factory installed electronic non-programmable/Man or Auto C/O thermostat and humidistat. "G" option can be used without CS2000A2 only if "X" or "B" ventilation option is used, unless other control provisions are field supplied to limit ventilation to occupied periods. ② Insert "D" for dehumidification with hot gas reheat. Reference Form F1744 for complete details. Dehumidification models have revision level one digit higher than standard models. Example: standard model QH362-Dehumidification model is QH363D.

## Required Field Installed Accessories - One Size/Color Must Be Used For Each Installation

### Outdoor Louver Grilles:

QLG-10 (for 2 - 3½ Ton Models)	QLG-15 (for 4 - 5 Ton Models)	Clear Anodized Aluminum
QLG-20 (for 2 - 3½ Ton Models)	QLG-25 (for 4 - 5 Ton Models)	Medium Bronze Anodized Aluminum
QLG-30 (for 2 - 3½ Ton Models)	QLG-35 (for 4 - 5 Ton Models)	Dark Bronze Anodized Aluminum

### Wall Sleeves: Note - Maximum dimension in inches of wall is shown ( )

For all 2 through 3½ ton units	QWS42A (14")	QWS42A-16 (16")	QWS42A-19 (19")	QWS42A-20 (20")	QWS42A-23 (23")	QWS42A-30 (30")
For all 4 through 5 ton units	QWS48A (14")	QWS48A-16 (16")	QWS48A-19 (19")	QWS48A-20 (20")	QWS48A-23 (23")	QWS48A-30 (30")

## Optional Field Installed Accessories - Additional Items As Determined By Job Specifications

### Drain Kit:

QCDS48A	Rear condensate drain system allows easy removal of unit from wall sleeve. <b>Fits all models.</b>
QCDS48H	Heated version of QCDS48 for freezing climates. 115 VAC, approximately 20W (requires separate circuit). <b>Fits all models.</b>

**NOTE:** The following accessory items must be selected so that the finish (color) is matched to the QH-model that they will be used with.

### Side Trim Extension Kits:

Required when wall thickness is less than 10½ inches and works for walls down to 6-inches thick. Used in place of standard trim kit supplied with unit to cover the space between unit and wall.

QSTX42A-V	Platinum vinyl	QSTX42A-4	Gray paint		<b>Unit Compatibility</b> All models
-----------	----------------	-----------	------------	--	---

### Free-Blow Plenum Boxes:

QPB42-V	Platinum vinyl	QPB42-4	Gray paint	Front supply, 4-way deflection grille	<b>Unit Compatibility</b> 2 - 3½ Ton
QPBS42-V	Platinum vinyl	QPBS42-4	Gray paint	Same as QPB42, plus 2-way deflection grille on each side	2 - 3½ Ton
QPB48-V	Platinum vinyl	QPB48-4	Gray paint	Front supply, 4-way deflection grille	4 - 5 Ton
QPBS48-V	Platinum vinyl	QPBS48-4	Gray paint	Same as QPB48, plus 2-way deflection grille on each side	4 - 5 Ton

### Top Fill Systems for Finishing Plenum Boxes to Ceilings:

QPBX42-9-V	Platinum vinyl	QPBX42-9-4	Gray paint	Use with QPB42 or QPBS42 (adjusts to ceilings up to 9' 6")	<b>Unit Compatibility</b> 2 - 3½ Ton
QPBX42-10-V	Platinum vinyl	QPBX42-10-4	Gray paint	Use with QPB42 or QPBS42 (adjusts to ceilings up to 10' 2")	2 - 3½ Ton
QPBX48-9-V	Platinum vinyl	QPBX48-9-4	Gray paint	Use with QPB48 or QPBS48 (adjusts to ceilings up to 9' 6")	4 - 5 Ton
QPBX48-10-V	Platinum vinyl	QPBX48-10-4	Gray paint	Use with QPB48 or QPBS48 (adjusts to ceilings up to 10' 2")	4 - 5 Ton

### Cabinet Extensions for Ducted Applications:

QCX10A-V	Platinum vinyl	QCX10A-4	Gray paint	20" height (adjusts for ceilings up to 9' 4"; add QPBX42-9 (-V or -4) for 9'4" to 10' finished ceiling heights)	<b>Unit Compatibility</b> 2 - 3½ Ton
QCX15A-V	Platinum vinyl	QCX15A-4	Gray paint	20" height (adjusts for ceilings up to 9' 4"; add QPBX48-9 (-V or -4) for 9'4" to 10' finished ceiling heights)	4 - 5 Ton

### Hot Water Coils with Plenum Boxes:

QPBHW42-F-V	Platinum vinyl	QPBHW42-F-4	Gray paint	Free-Blow plenum box	<b>Unit Compatibility</b> 2 - 3½ Ton
QPBHW48-F-V	Platinum vinyl	QPBHW48-F-4	Gray paint	Free-Blow plenum box	4 - 5 Ton
QPBHW42-D-V	Platinum vinyl	QPBHW42-D-4	Gray paint	Ducted plenum box	2 - 3½ Ton
QPBHW48-D-V	Platinum vinyl	QPBHW48-D-4	Gray paint	Ducted plenum box	4 - 5 Ton

**NOTE:** The same top fill system and cabinet extensions can be used with hot water coil plenum boxes as with standard plenum boxes.



Bard Manufacturing Company, Inc.  
Bryan, Ohio 43506  
www.bardhvac.com

**Due to our continuous product improvement policy, all specifications subject to change without notice.**

Before purchasing this appliance, read important energy cost and efficiency information available from your retailer.

Form No.  
S3349  
February, 2009

Supersedes S3349-608